

# PYROLYTIC BOILERS ROJEK

## PK 20, 25, 30, 40, 49, 60

*upper loading*

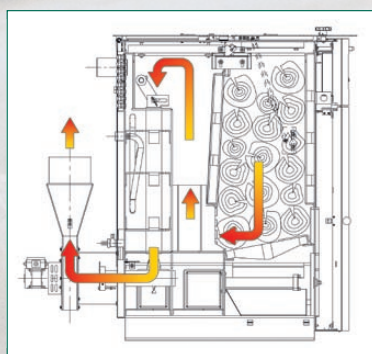
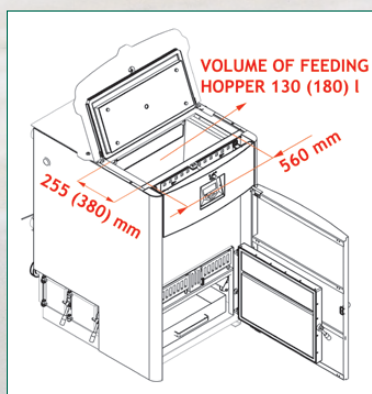

Manual loading wood length 530 mm and brown coal (fraction 20-40 mm).



Pyrolytic boilers **ROJEK PK** have upper loading of combustion chamber which enables using the complete volume of combustion chamber not only for piece wood (wood length 530 mm), but also for loose material, e.g. short piece wood – a product of ROJEK DH 10 wood crushers or wood briquettes, and brown coal (fraction 20-40 mm).

Pyrolytic boilers ROJEK PK are recommended to be used in combination with ROJEK storage tanks.



## Advantages of pyrolytic boilers ROJEK PK

- Loading of combustion chamber of the boiler is very easy and quick by lifting off the loading door.
- Bigger volume of combustion chamber (PK 20 – 30: 130 dm<sup>3</sup> = 130 l, PK 40 – 60: 180 dm<sup>3</sup> = 180 l)
- High efficiency 87,7 – 90,1%.
- Max. length of wood 530 mm for all nominal powers (wood moisture max. 20%)
- Longer time for burn-up of combustion chamber up to 7 hours depending on quality of wood and boiler power.
- Quick start of ROJEK PK boilers due to bigger space of boiler body and exchanger that are evenly filled with water – volume 98 l.
- Easy cleaning of exchanger by means of a handle and cleaning door accessible from outside (right or left execution of cleaning handle).
- Boilers comply with class 3 in accordance with the Norm ČSN EN 303-5.
- Boilers are controlled by electronic control unit that controls: exhaust fan, water temperature in boiler – switching on the pump and switching off the fan, control of water temperature (min. – max.), manual or automatic operation (several different variants of automatic operation), time for fuel burn-up, manual operation for firing, adjustable speeds of fan, exhaust sensor, boiler and regulator protection, sound alarm, choice of languages.



### The regulator is provided with programme zPID.

In addition to standard sensors the regulator is also provided with exhaust sensor. It controls exhaust temperature and temperature of boiler water. Based on their values the control changes the speed of fan in order to maintain the adjusted temperature of boiler water.



### Algorithmus PID (proportional-integral-derivate) is used in automatics and consists of following values:

P – proportional, kP – increase P, I – function, Ti – time multiplication, D – differential value and Td – time advance.

Its intention is to maintain starting values on a certain level.

Algorithmus PID is used for temperature process control, in that case it works as a very accurate thermostat. That means the regulator with function zPID works based on algoritmus PID supported by exhaust sensor.

**Using this type of regulator with exhaust sensor up to 13% fuel can be saved, the temperature of exit water is very stable which has influence on longer operation life of the exchanger (boiler). Control of exhaust temperature on exit from boiler causes low emission of dust and gases dangerous for the environment. Thermal energy is fully used for water heating and does not escape to the chimney.**

### Boiler control



## Technical data of pyrolytic boilers ROJEK PK

Data	Unit	PK 20	PK 25	PK 30	PK 40	PK 49	PK 60
Nominal power wood / brown coal *	kW	20 / 20	25 / 24	30 / 28	36 / 40	43 / 49	50 / 60
Efficiency wood / brown coal *	%	90,1 / 85,7	88,9 / 85,5	87,7 / 85,4	84,8 / 84,5	81 / 84	79,4 / 83,5
Chimney diameter	mm	159					
Power input (230V/50Hz)	W	76					
Volume of feeding hopper	l	130			180		
Volume of water	l	98			130	130	151
Connection diam. for water inlet and outlet	DN	G 2"					
Rated chimney draught wood / brown coal *	Pa	10 - 18 / 14 - 19					
Consumption of wood / brown coal * at nominal power	kg / h	6,5 / 4	8 / 5	9,7 / 5,6	11,8 / 8	13,9 / 9,8	16,1 / 11,2
Boiler class in accordance with the Norm ČSN EN 303-5		3					
Max. water overpressure	bar	2					
Max. wood diameter / length	mm	250 / 530					
Min. operation temperature	°C	63					
Boiler weight	kg	505			615		665
Temperature of combustion gases at nominal power	°C	220 - 250 (wood), 170 - 210 (brown coal*)					

\* Brown coal (fraction 20-40 mm).

Data and pictures in this leaflet have informative character. Technical and optical changes are possible without previous advise.



www.rojek.cz

**ROJEK prodej, spol. s r.o.**  
Masarykova 16, 517 50 Častolovice, Czech Republic

Tel.: +420 494 339 140, Fax: +420 494 323 341

e-mail: export@rojek.cz

Your dealer:



THE EUROPEAN REGIONAL DEVELOPMENT FUND AND THE MINISTRY OF INDUSTRY AND TRADE OF THE CZECH REPUBLIC SUPPORT INVESTMENT IN YOUR FUTURE.